

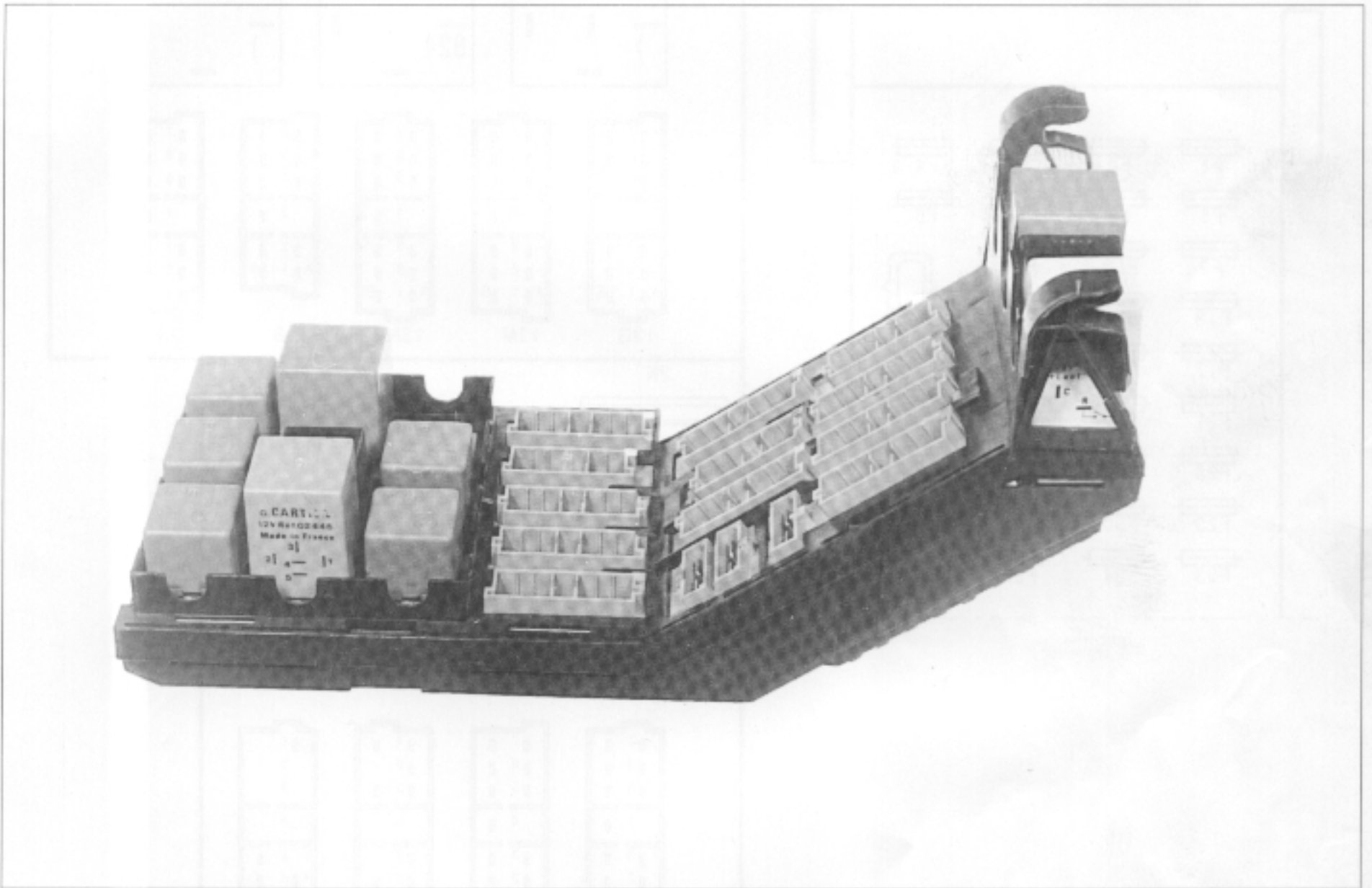

50



89-536



52

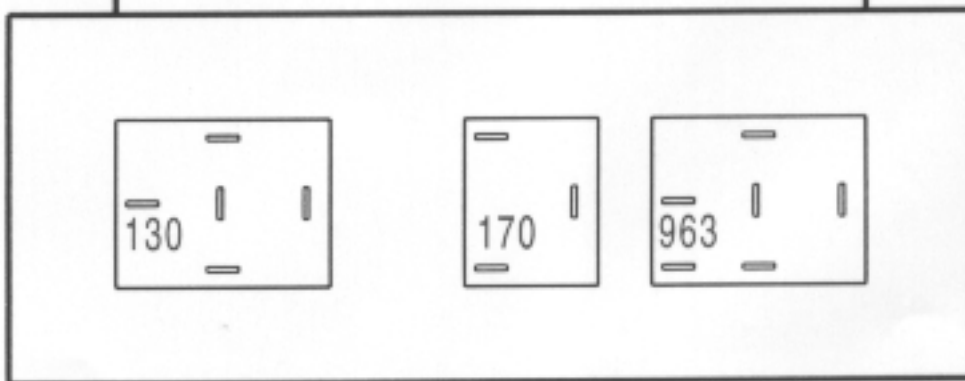
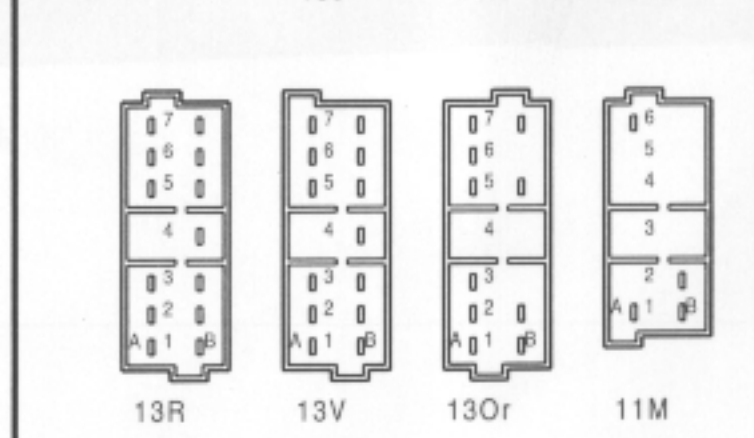
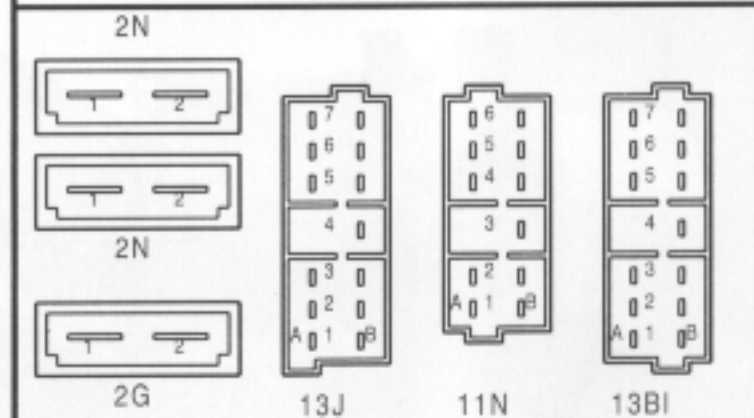
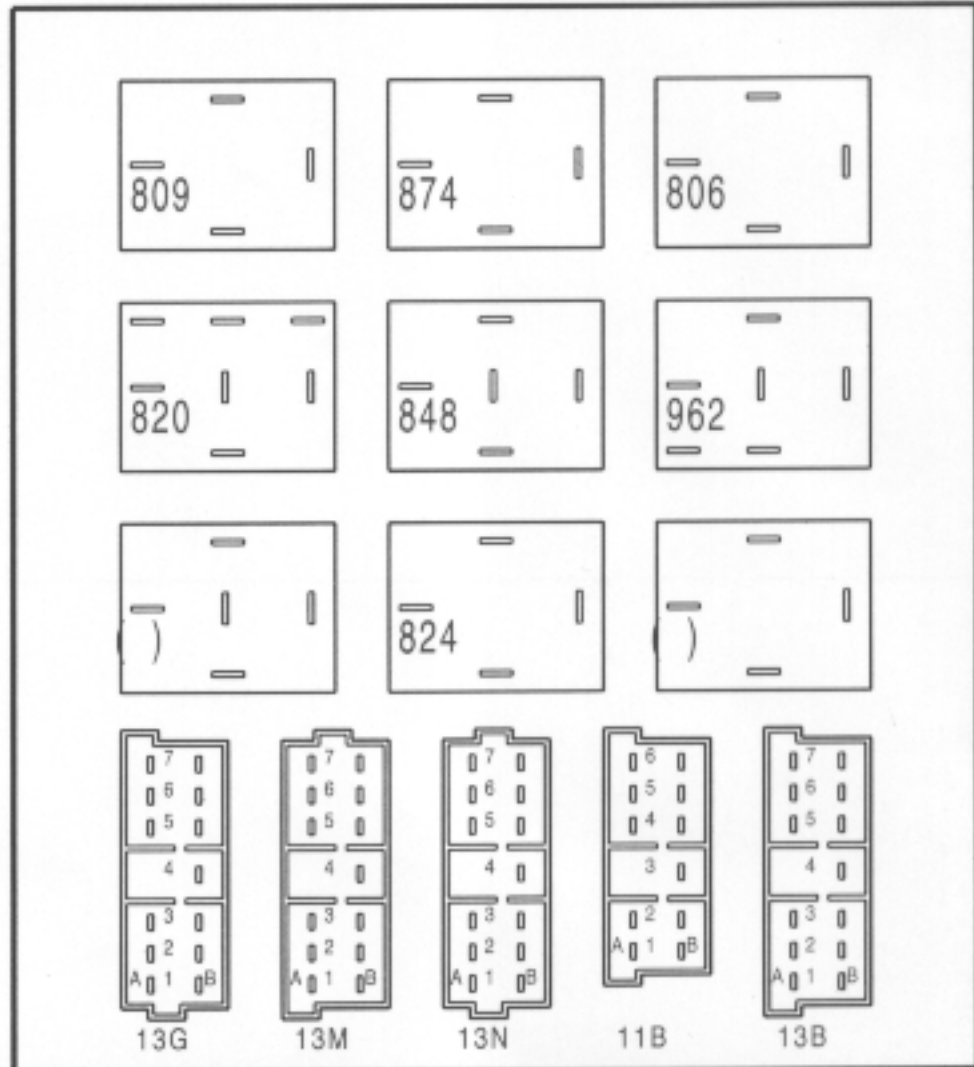
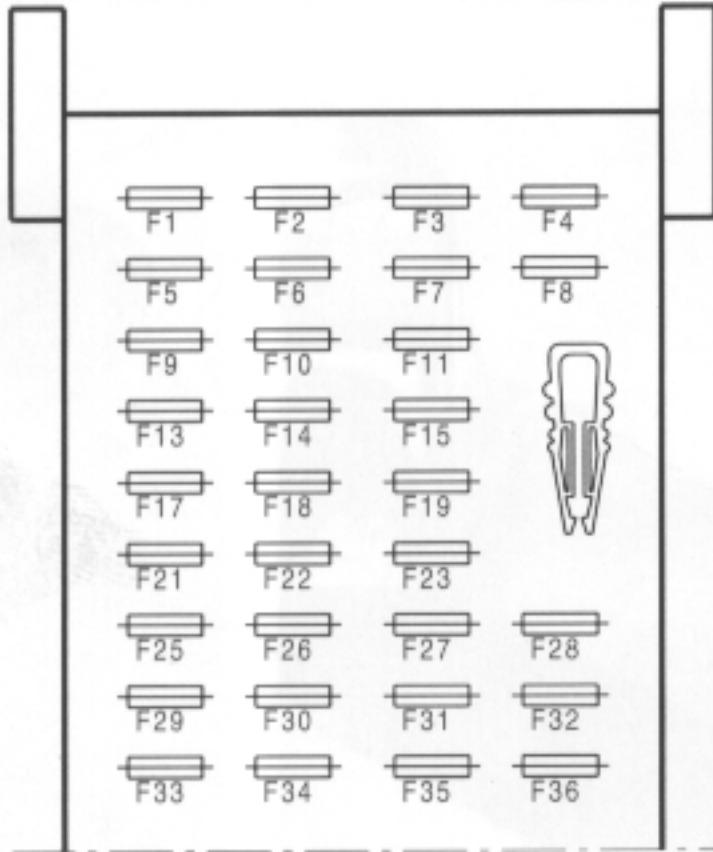





50

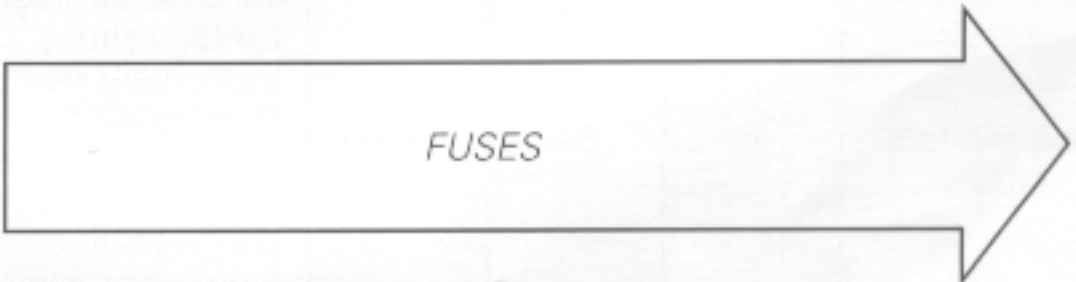
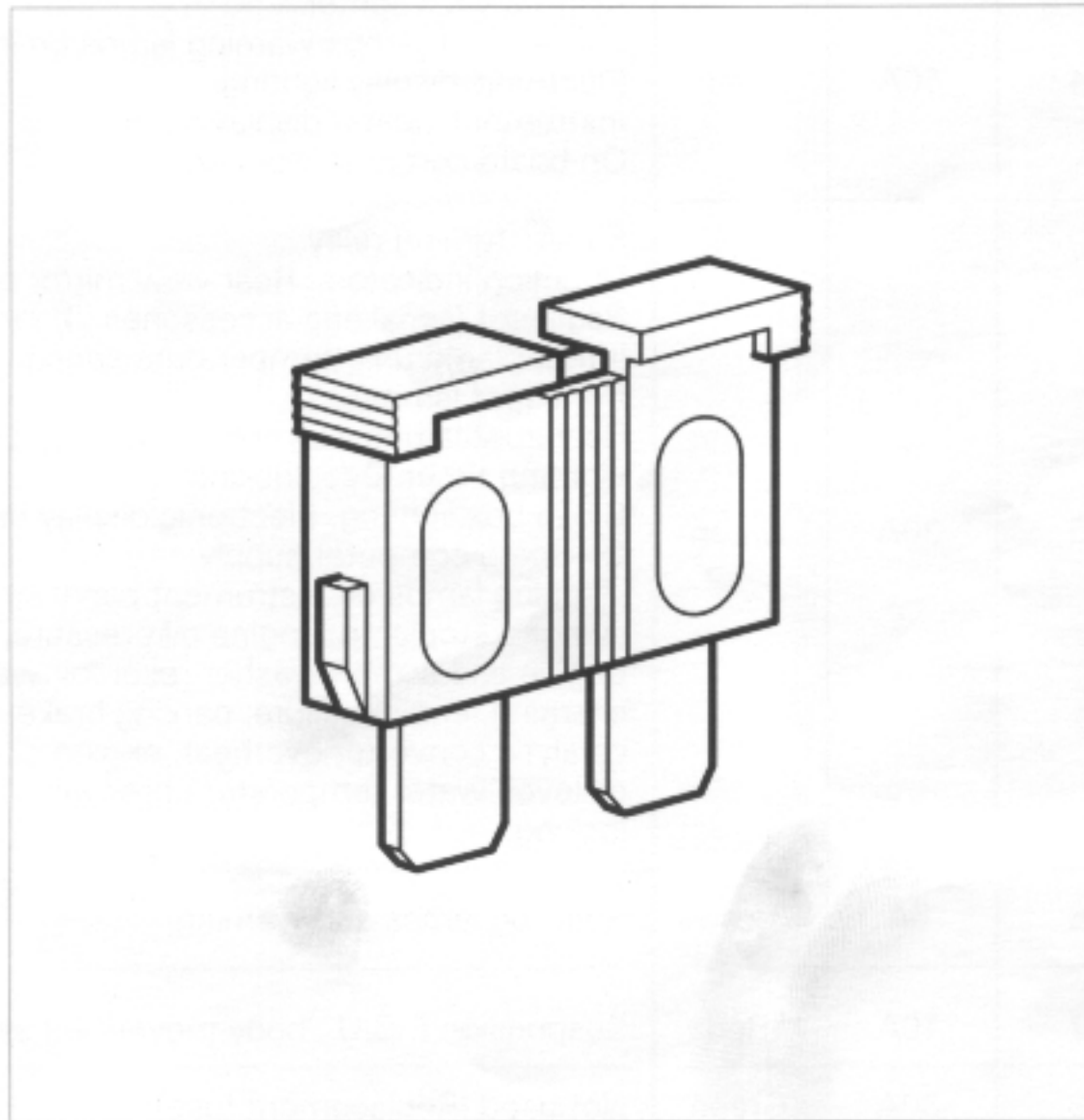

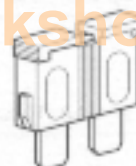

## 1° JUNCTION BOX

SUPPLY	FUSES			PROTECTED CIRCUITS
	No	Rating	Colour	
+ Accessories	1	10A	Red	Anti-lock brake system.
	2	10A	Red	Stop lamps and brake pad wear warning lamp, cruise regulation Water temperature control unit. Hydraulic system audible warning.
	3	10A	Red	Air conditioning, heated rear screen, heated seats, heated rear view mirrors relays.
Side and tail lamps	4	10A	Red	Alarm switch lighter. Side and tail lamps warning lamps on instrument panel. Electronic display lighting. Instrument cluster display lighting. On-board computer lighting.
+ Accessories	5	30A	Green	Engine turning relay. Direction indicators. Rear view mirror operation. Radio set (aerial and accessories ), radio-telephone. Interior lamp unit (temperature sensor turbine and centre and front spot lamps). Rear spot lamps, rear view mirror lighting. Lighting timer. Deadlocking. Glove box lighting. Electronic display unit. On-board computer supply. Warning lamps on instrument panel strip for : hydraulic system, stoplamp, engine oil pressure, water temperature, engine and screen washer reservoir water level, battery charging, engine failure, parking brake, water-in-fuel filter, catalytic converter overheat, engine oil temperature, engine oil level, water temperature pre-warning, driver's seat belt locking.
Rear fog lamps	6	5A	Brown	Rear fog lamps and warning
	7	10A	Red	Suspension E.C.U., body movement sensor.
	8	30A	Green	Not used (Replacement fuse)
+ Accessories	9	30A	Green	Relay coils for : electric front and rear windows, sun-roof Electronic timer units for front and rear screen wipers. Front and rear screen wiper/washer motors. L.H. and R.H. front seats operation relay coils. Lights-on audible warning. Electric cooling fan relay coils (slow speed).
Side and tails lamps	10	5A	Brown	Illumination for switches of : rear door functions, electric window, armrest operation, cruise control, car radio, cigar lighter, ashtray, radio set. Instrument cluster lighting. Illumination for switches of : front and rear foglamps, screen washer, rear screen wiper, heated rear screen, hazard warning device, interior lamp, suspension, sun-roof, air conditioning control, air conditioning. Side lamps and rear number plate lamp. Headlamp washer relay. Lights-on audible warning.



50

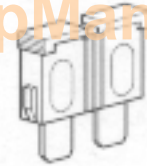

SUPPLY	FUSES			PROTECTED CIRCUITS
	No	A	Colour	
Electronic display unit	11	5A	Dark brown	Display unit language
	12			No fuse
+ Battery	13	10A	Red	Hazard warning device
Side lamps	14	5A	Dark brown	R.H. tail lamps
Electronic display unit	15	5A	Dark brown	Display unit language
	16			No fuse
+ Battery	17	30A	Green	Heated rear seats and seat backrests
Side lamps	18	5A	Dark brown	L.H. tail lamps
	20			No fuse
Side lamps	21	15A	Blue	Front and rear fog lamps and warning lamps
+ Battery	22	30A	Green	Radio telephone. Anti-theft horn. Deadlocking control unit. Remote control deadlocking control unit.
+ Ignition	23	15A	Blue	Speed sensor. Interior lamp lighting timer. Coolant level control unit. Automatic gearbox. Reversing lamps, alarm siren. Coils for refrigeration compressor cut-off relay, lighting timer and day time lamps Engine water temperature, alarm and rear view mirror setting control units Instrument clusters : tachometer and oil temperature gauge, water temperature gauge, electronic system supply, road wheel ABS.
	24			No fuse
+ Battery	25	30A	Green	Sun roof
+ Battery	26	20A	Yellow	Not used (replacement fuse)
+ Battery	27	20A	Yellow	On-board computer memory. Electronic system instrument cluster, clock. Doors and boot sill lightings. Interior lamps and interior lamp timer units. Horns.
+ Battery	28	30A	Green	Passenger's front seats operations.
+ Battery	29	30A	Green	Driver and passenger's electric front windows. Rear view mirrors operation control unit.
+ Battery	30	30A	Green	Driver's seat operations.
+ Battery	31	30A	Green	Electric rear windows. Anti-pinch electric front window.
+ Battery	32	30A	Green	Headlamp washer pump.
+ Battery	33	30A	Green	Heated rear screen and heated rear view mirrors.



SUPPLY	FUSES			PROTECTED CIRCUITS
	No	A	Colour	
+ Battery	34	30A	Green	Water temperature control unit. Central door locking control unit. PLIP remote control control unit. Hydractive suspension system. Alarm. Burglar alarm relay coil. Burglar alarm warning lamp.
+ Battery	35	30A	Green	Front heated seats. Front centre armrest adjusting motor. Cigar lighter.
+ Battery	36	30A	Green	Cigar lighter. Car radio memory.