

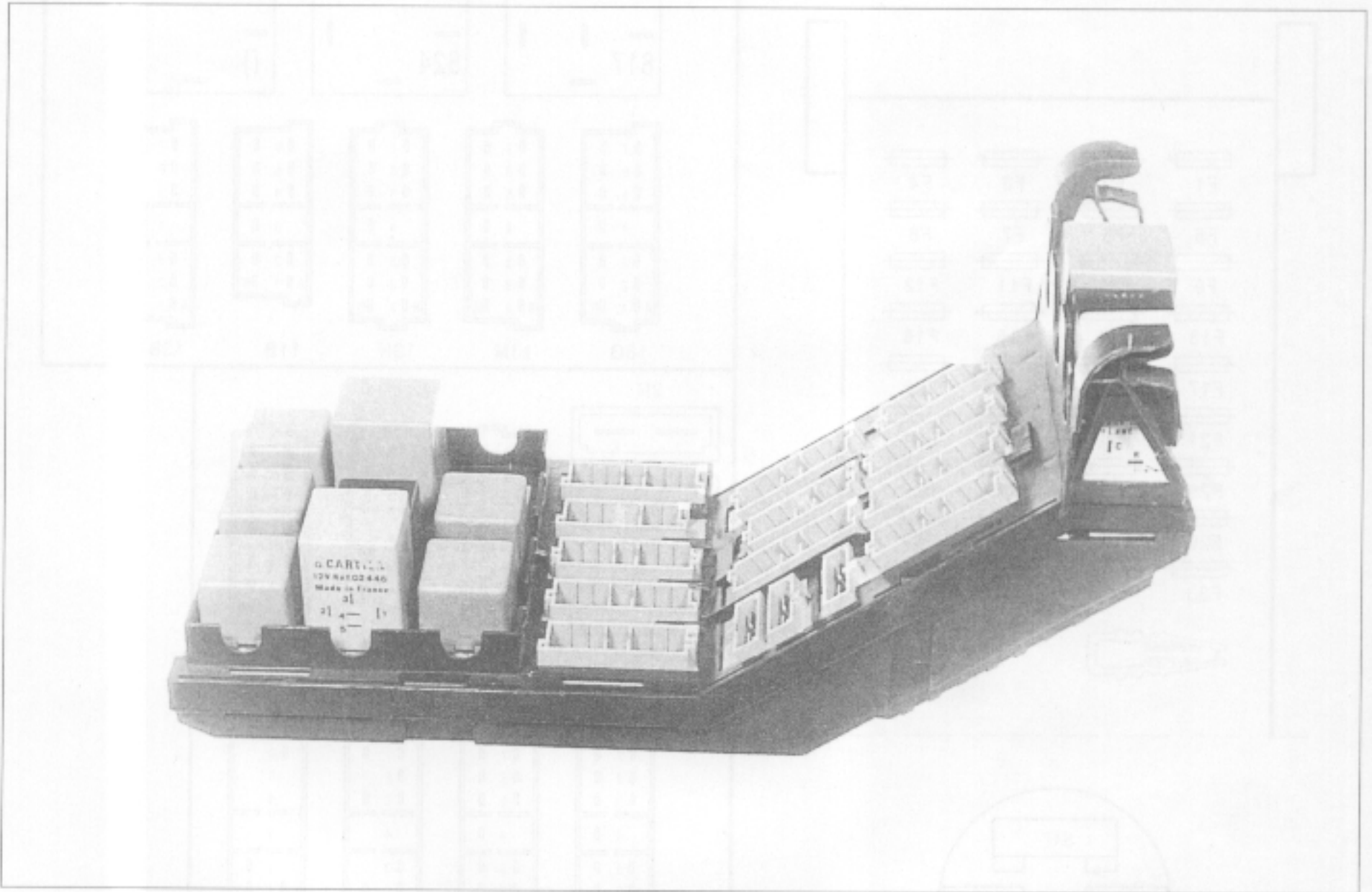

50



89-536



52

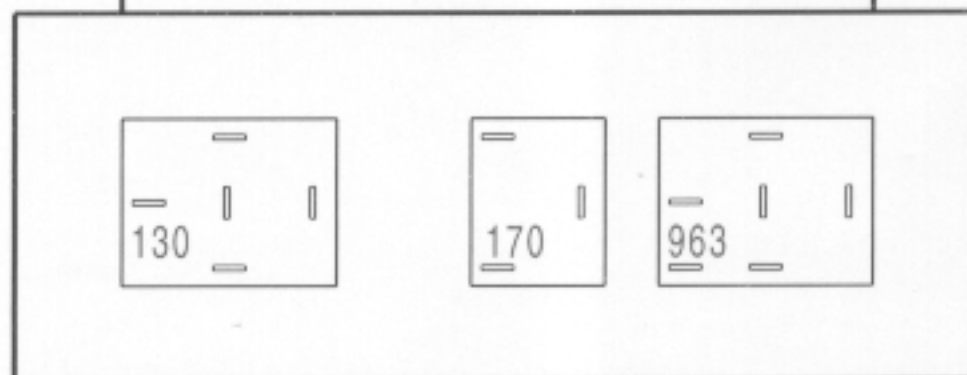
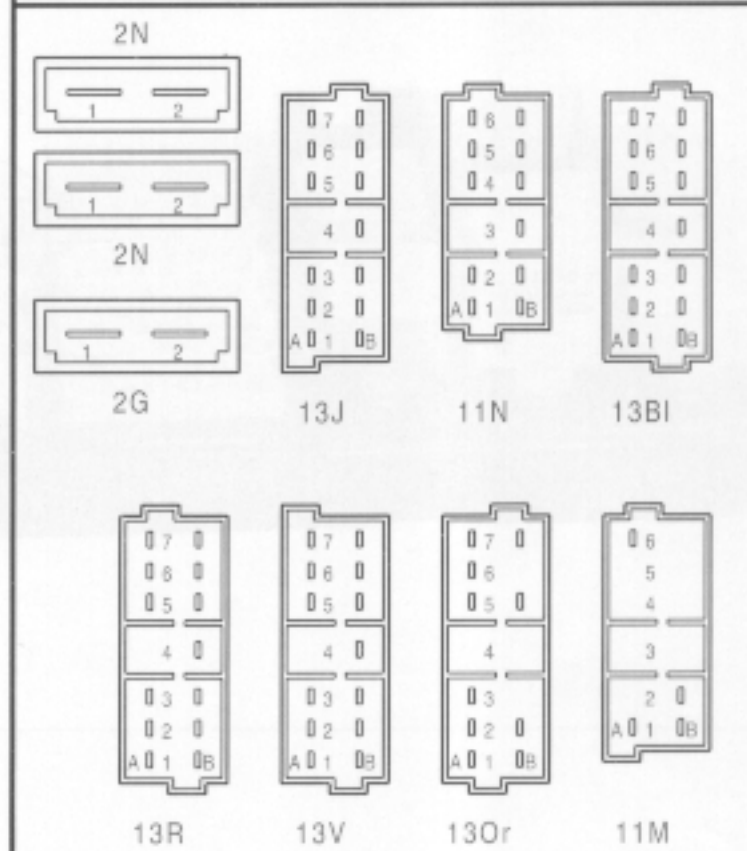
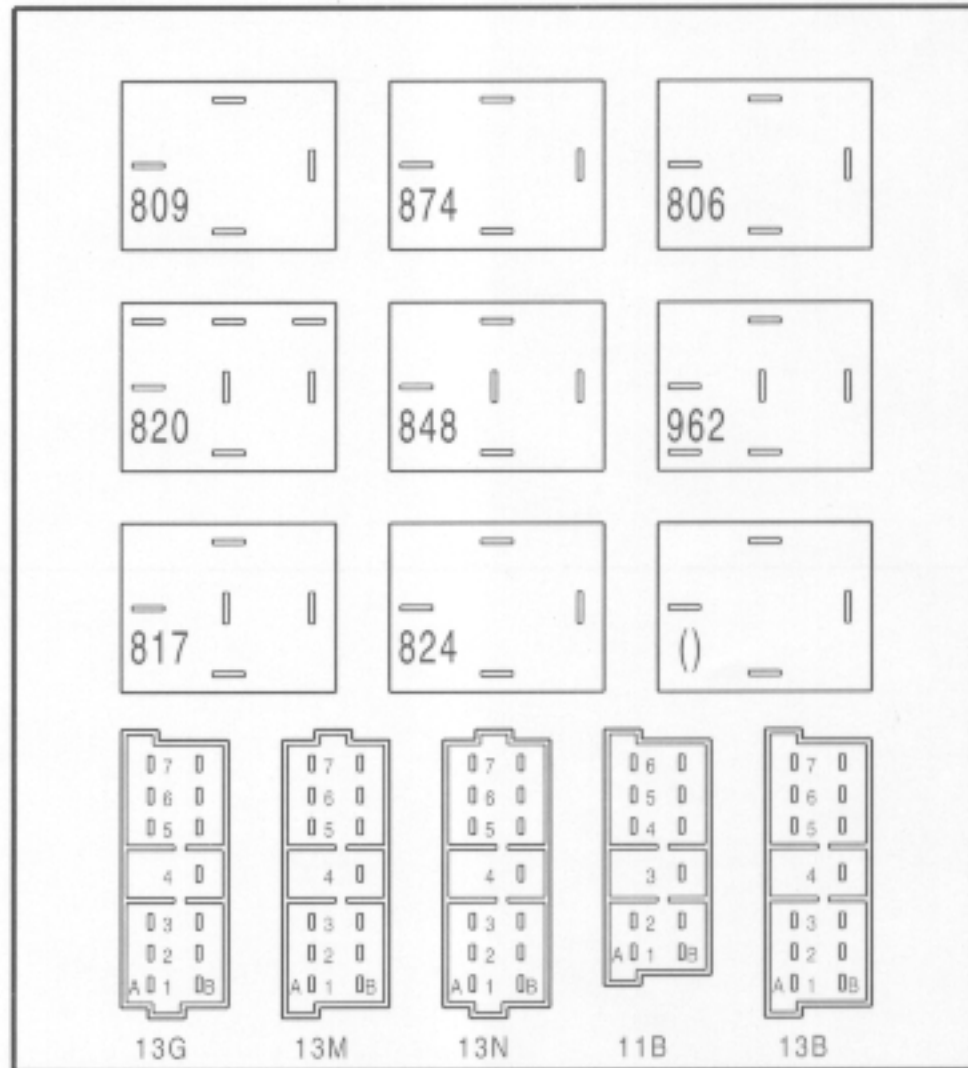
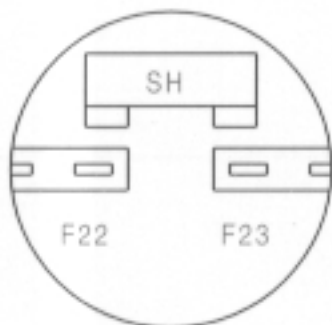





50



### 1° JUNCTION BOX

#### PROTECTED CIRCUITS

#### FUSES

#### SUPPLY

No. Rating Circuit

No.	Rating	Circuit	SUPPLY
1	10A	Accessories	+ Accessories
2	10A	Ignition	+ Accessories
3	10A	Front lighting	+ After ignition switched off

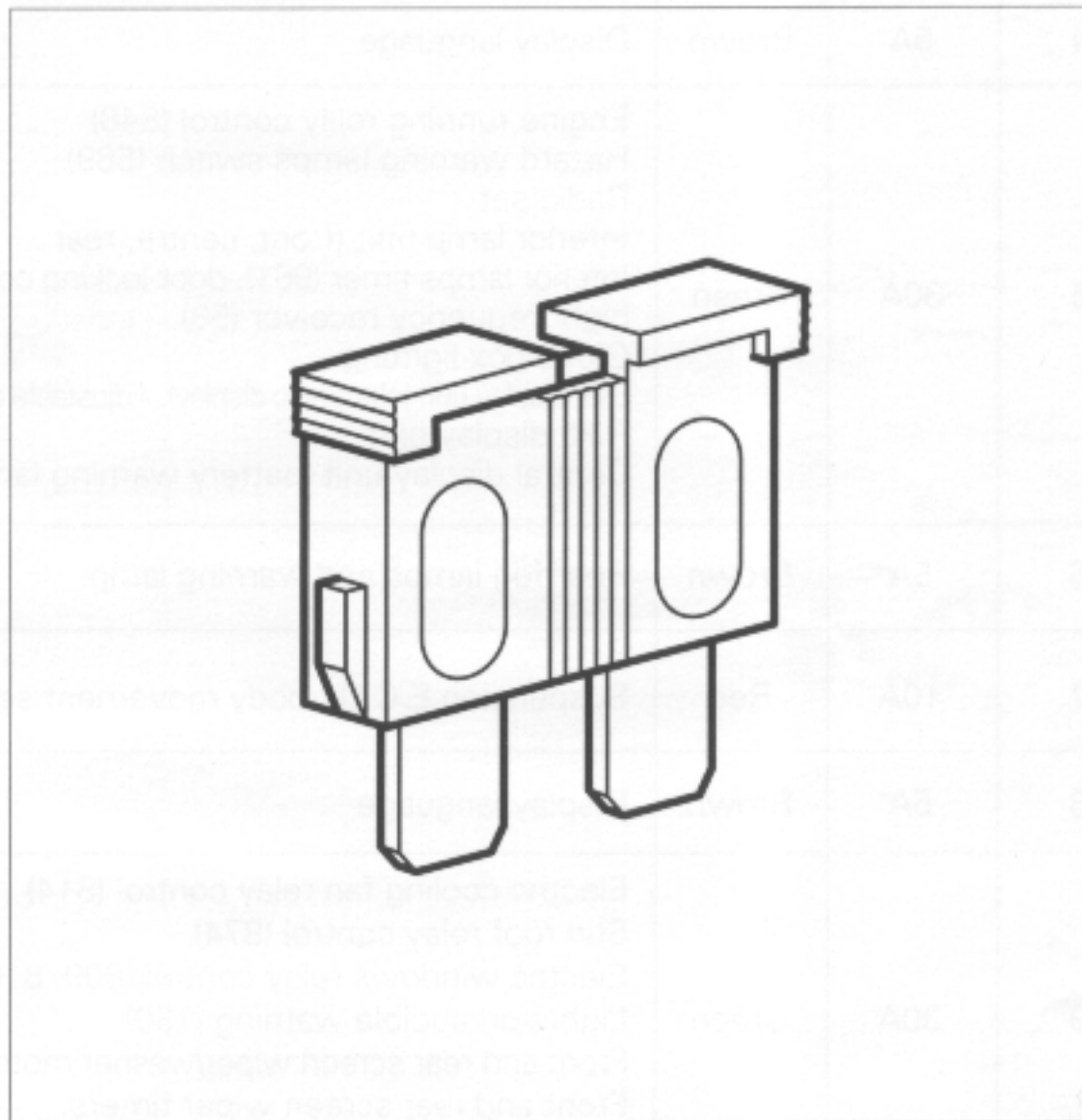



## 1° JUNCTION BOX

SUPPLY	FUSES			PROTECTED CIRCUITS
	No	Rating	Colour	
+ Accessories	1	10A	Red	ABS system.
+ Accessories	2	10A	Red	Stoplamp function Cruise control Water temperature control unit.
+ After ignition switched off	3	10A	Red	Air conditioning relay control (821), Front heated seats relay control (817, 824) Heated rear screen/rear view mirrors delay timer (820)
Electronic display unit	4	5A	Brown	Display language
+ Accessories	5	30A	Green	Engine running relay control (848) Hazard warning lamps switch (589) Radio set Interior lamp unit (front, centre, rear ... spotlamps) Interior lamps timer (961), door locking control unit (55) and high frequency receiver (58) Glove box lighting L.H. display unit (electronic display). Adjustable rear view mirror function R.H. display unit Central display unit (battery warning lamp)
Rear fog lamps	6	5A	Brown	Rear fog lamps and warning lamp.
+ After ignition switched off	7	10A	Red	Suspension E.C.U., body movement sensor.
Electronic display unit	8	5A	Brown	Display language
+ Accessories	9	30A	Green	Electric cooling fan relay control (814) Sun roof relay control (874) Electric windows relay control (809, 810) Lights-on audible warning (130) Front and rear screen wiper/washer motors and switches: Front and rear screen wiper timers. Overspeed audible warning.
+ Side and tail lamps	10	10A	Red	Illumination for switches of : rear locking functions, electric window, armrest operation, cruise control, cigar lighter, radio flap, ashtrays Instrument cluster and radio lighting. Illumination for switches of : front and rear fog lamps, screen washer, rear screen wiper, heated rear screen, hazard warning device, interior lamp, suspension, sun roof, air conditioning control, air conditioning. Front side lamps and rear number plate lighting Headlamp washer relay. Lights-on audible warning.
+ Side and tail lamps	11	10A	Red	Cruise control and alarm switches lamps Electronic display lighting Instrument cluster display lighting On-board computer lighting Clock lighting



50

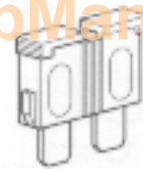

SUPPLY	FUSES			PROTECTED CIRCUITS
	No	Rating	Colour	
Electronic display unit	12	5A	Brown	Display language
+ Battery	13	10A	Red	Diagnostic connector Hazard warning lamps
+ Side and tail lamps	14	5A	Brown	Rear R.H. sidelamps.
+ After ignition	15	5A	Brown	Water temperature control unit
+ After ignition	16	5A	Brown	High temperature warning lamp
+ Battery	17	20A	Yellow	Rear heated seats relay power (824)
+ Side and tail lamps	18	5A	Brown	Rear L.H. sidelamps
+ After ignition	19	15A	Blue	Speed sensor. Interior lighting timer unit Coolant level control unit, automatic gearbox Reversing lamps, alarm siren. Coils for refrigeration compressor cut-off relay Day time lamps. Engine water temperature, alarm and rear view mirror setting E.C.U.s. Instrument clusters : tachometer and oil temperature gauge water temperature gauge, electronic system supply, ABS warning lamp Central display unit (warning lamps) Diagnostic connector Catalytic converter control unit
+ Battery	20	5A	Brown	Not used (Replacement)
+ Battery	21	15A	Blue	Fog lamp relay power (806)
+ Battery	22	Shunt		Factory arrangement : F15 (no fuse) F22 (no fuse) F23 (30A fuse) Consequence : fuses F27, F31 and F35 are supplied with with "+ after ignition".
+ After ignition	23			Customer arrangement : F23 fuse moved at F15 Shunt fitted between F22 and F23 Consequence : fuses F27, F31 and F35 are supplied with "+ battery"
+ Battery	24	20A	Yellow	Front heated seats relay power (817)
+ Battery	25	20A	Yellow	Sun roof relay power.
+ Battery	26	30A	Green	Electric rear window relay power (810)
+ Battery (with shunt)	27	15A	Blue	Car radio Alarm : control unit, LED, alarm relay control Interior lighting timer Instrument cluster electronic assembly R.H. display unit Boot lighting



SUPPLY	FUSES			PROTECTED CIRCUITS
	No	Rating	Colour	
+ Battery	28	30A	Green	R.H. front seat operations
+ Battery	29	15A	Blue	Not used (Replacement)
+ Battery	30	30A	Green	L.H. front seat operations
+ Battery (with shunt)	31	10A	Red	Water temperature control unit Injection E.C.U.
+ Battery	32	30A	Green	Headlamp washer pump Horns
+ Battery	33	30A	Green	Heated rear screen/rear view mirror delay timer (820)
+ Battery	34	30A	Green	Central door locking control unit. PLIP remote control control unit. (I.R.) Hydractive suspension system. Anti-theft alarm relay power (795). Central locking control unit + H.F. receiver
+ Battery (with shunt)	35	30A	Green	Electric front window relay power (809) Electric window anti-pinch motor
+ Battery	36	30A	Green	Front and rear cigar lighter